

TECHNICAL DATA

- Power supply: 230V AC 50Hz
- Optional: 240V, 220V, 200V, 120V, 100V AC 50/60Hz
- Power consumption: 480W at 220V
- Lamp: MSD 250W discharge lamp (Working life: 2000h)
- Control: DMX 512
- Running model: Stand-alone / Controller
- Colours: 6 dichroic colours plus white and rainbow effect
Cyan, Yellow, and Magenta colours
- Shutter/Strobe: 2 Blade shutter for dimming, adjustable from 1~7 F.P.S.
- Effects beam: Soft/focus beam, magnifying/lessening image by adjusting Fresnel lens
- Movement: Pan movement 370° -Tilt movement 265°
- Net weight: 20.1kg
- Others: Auto thermal cut-off

DIMENSIONS AND LIGHT OUTPUT

DIMENSIONS

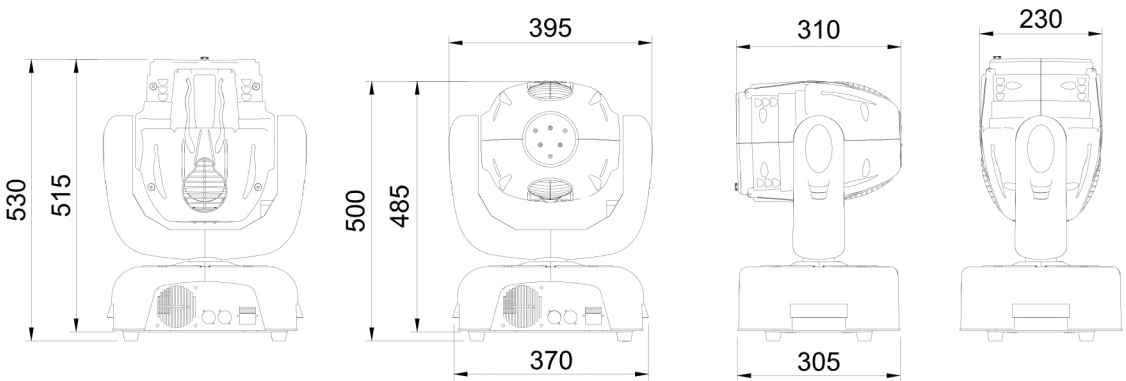

LIGHT OUTPUT

